

# BriPower ESD Series Programmable DC Power Supply

## Features

- Single system up to 500kW, up to 4MW and above
- Output voltage up to 2000V(std)
- Applications: battery simulation, battery test (-BSS option), PV simulation (-PV option)
- Program accuracy up to 0.1%
- Seamless transition between source and sink modes (-R option)
- Current rise time (0 -90%) <1ms (-BSS option)
- Soft start: effectively restrain the impulse current when power on
- CC/CV/CP/CR mode available
- Regenerative DC load function (-LD option)
- Hardware & software for PV Simulation (-PV option)
- Low-Voltage operation mode (-ZV option)
- Master-Slave interface (-MS option)
- Use water-cooling (-W option)
- LAN/RS485 interfaces (standard)
- CAN/RS232/ATI interfaces (-CAN/-232/-ATI option)
- Emergency stop button and indicators on front panel
- TFT-Touch panel operation
- Mod-bus/SCPI protocols

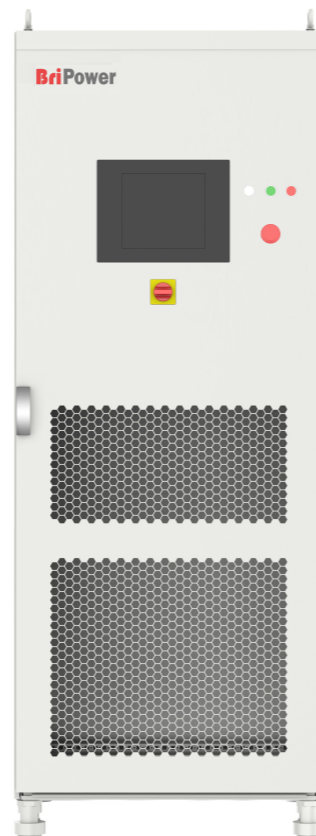

- Output terminal insulation monitoring function (-INS option)
- Output contactor
- Remote sense
- CE conformity
- 13 months warranty

## Overview

The BriPower ESD series is IGBT PWM switching DC power supply, which contains multi output power levels from 30kW to 500kW for single system, up to 4 individual systems can be paralleled to up to 2MW system. Output power level of customized system goes up to 4MW and above.

ESD series uses bi-directional design, which makes it possible to be used as DC power source or regenerative DC load. CV/CC/CP/CR operation modes are available for both sourcing and sinking.

ESD series adopts dual DSP+FPGA design, with powerful calculation and control capabilities, and can display and save measured values at 10k/s sampling. The ESD series adopts optical fiber communication and performs multiple monitoring and protection of all main components, communication connections and systems. It is a reliable power supply product.

With touch panel on the front panel, users can control the power source through GUI software. System status indicators and emergency stop button are installed on the front panel. RS485 and LAN standard interface, optional CAN, RS232 and analog control interfaces are available for automated test applications.

## Bi-Directional (Re-generative) –R option

With the -R option, the unit can operate in source and sink mode. It has the capability to return the energy fully back to the grid.

## Re-regenerative DC Load –LD option<sup>1</sup>

ESD series with -LD option can be used as regenerative DC electronic load. DC load simulation includes constant current, constant resistance, constant voltage, and constant power modes.

<sup>1</sup> -The LD option must be used in combination with the - R option.

## Low Voltage Operation Mode -ZV option

ESD series DC electronic load with -ZV option can produce large current that meets the requirements under the input condition close to 0.4V, which can evaluate the electrical characteristics of the fuel cell (such as VI), etc.

## Automatic wide range output

ESD series DC power supply has an automatic wide-range output function. Under the condition of rated output power, the output range of voltage/current can be adjusted, such as: high-voltage small current or low-voltage large current (also applicable in sink power mode). The same type of power supply can cover a wider range of power applications. ESD standard models provide x1/x3/x4 current. For customized power/voltage/current, please consult the factory.

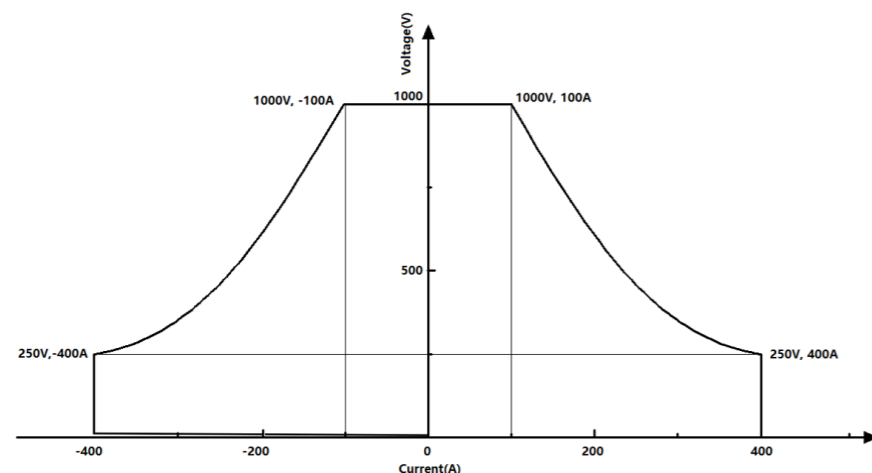

Example: 100kW, 1000V, ±400A

## Fast current rising

ESD Series has excellent dynamic performance of current rising, which makes it ideal for battery test and battery simulation. Two versions are provided, and current rise time of each version is different.

Current Rise Time (0~90%)	<3ms (Std), <1ms (BSS Option)
Current Rise Time (-90%~90%)	<5ms (Std), <2ms (BSS Option)
Voltage Regulation Time	<3ms (Std), <1.5ms (BSS Option) (0-100% Load change)

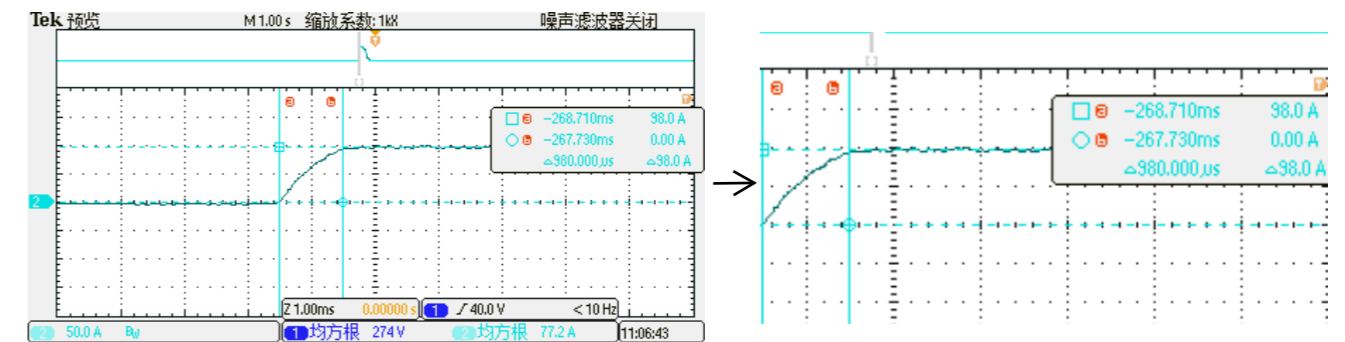

Current Rise Time (0%~90%)  $T_{Rise} \leq 1ms$  (Example ESD 50-400-125-R)

## Battery Test

ESD series DC power supply can be used for characterization of power battery packs. It is used to test the charging and discharging performance, temperature rise characteristics, and cycle life of the power battery pack. Through the GUI software, different charging and discharging profiles can be programmed, and test results are displayed in real time.

## Battery Simulation

ESD Series DC power supplies provides GUI software to simulate the charging and discharging characteristics of the power battery pack/package and it provides battery simulation software, which can simulate different types of batteries, lithium-ion batteries, etc., supporting multiple parameter settings, including: battery capacity, the number of cells in series and parallel, the state of charge, etc.

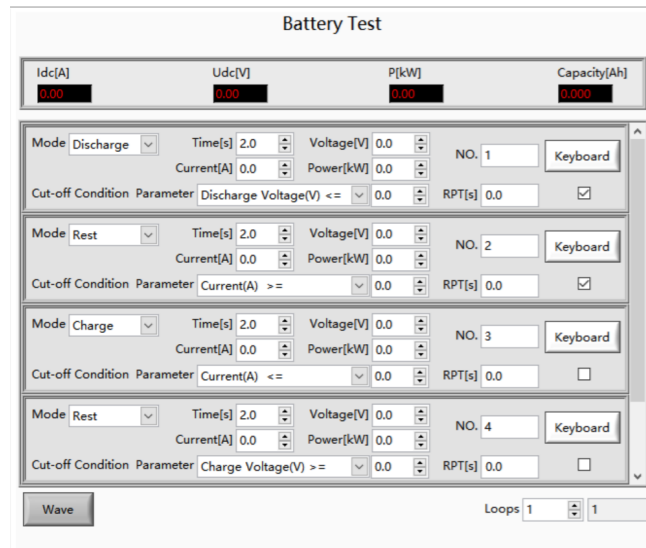

Battery Test

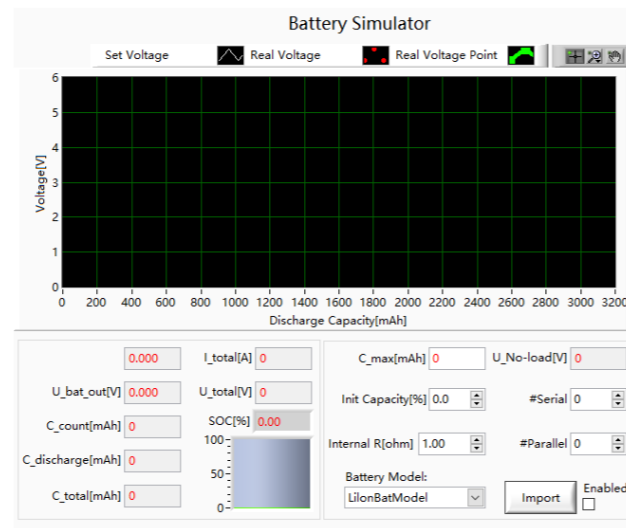

Battery Simulation

## PV Simulation (-PV Option)

With -PV option, ESD series power supplies can be used to simulate IV curves of various solar panels, under various temperature and irradiance condition, and conduct static and dynamic MPPT tests according to EN 50530: 2010.MPP update rate: 200Hz. Irradiance levels: 0 ~ 1500 W/m<sup>2</sup>. Temperature: -10 ~ +100°C. Temperature coefficient: +1% ~ -1%/°C.

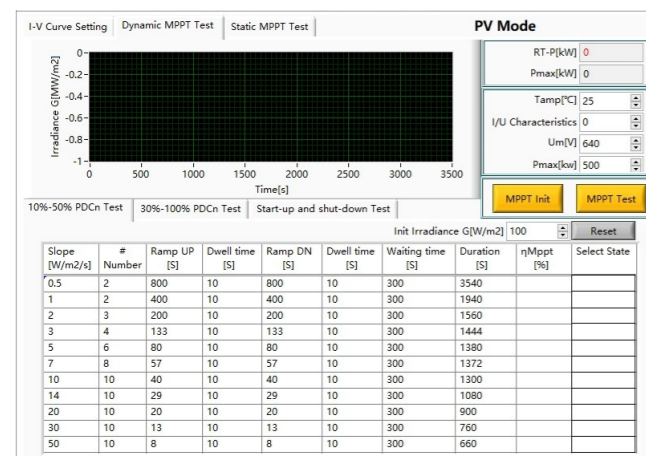

Dynamic MPPT test

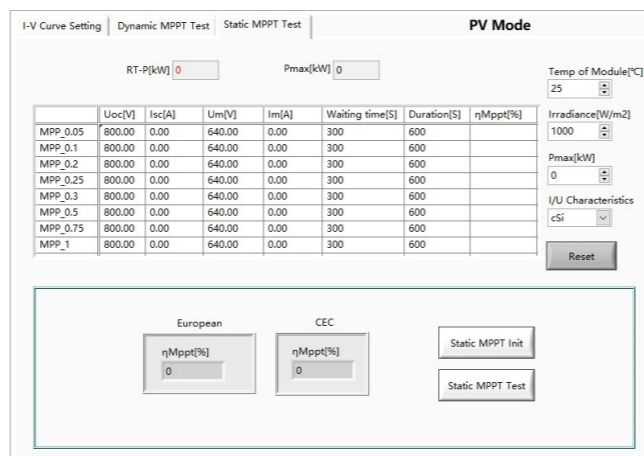

Static MPPT tests

## Graphical User Interface

GUI software is installed in front touch panel, which uses Windows OS. The software provides

following functions:

- Output settings and limits
- Sequence output settings
- Display measurements: voltage, current, power, etc.
- Capture, display and save output voltage and current waveforms
- Display power source faults

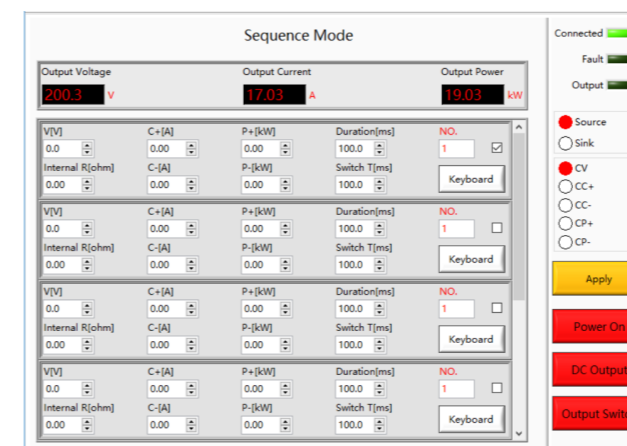

Sequence Programming

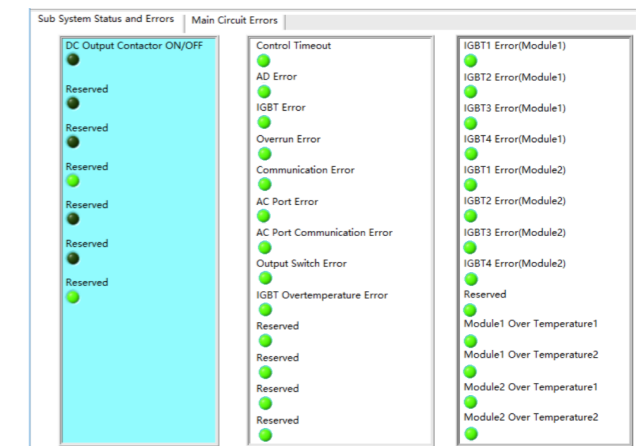

System Status

## Block Diagram

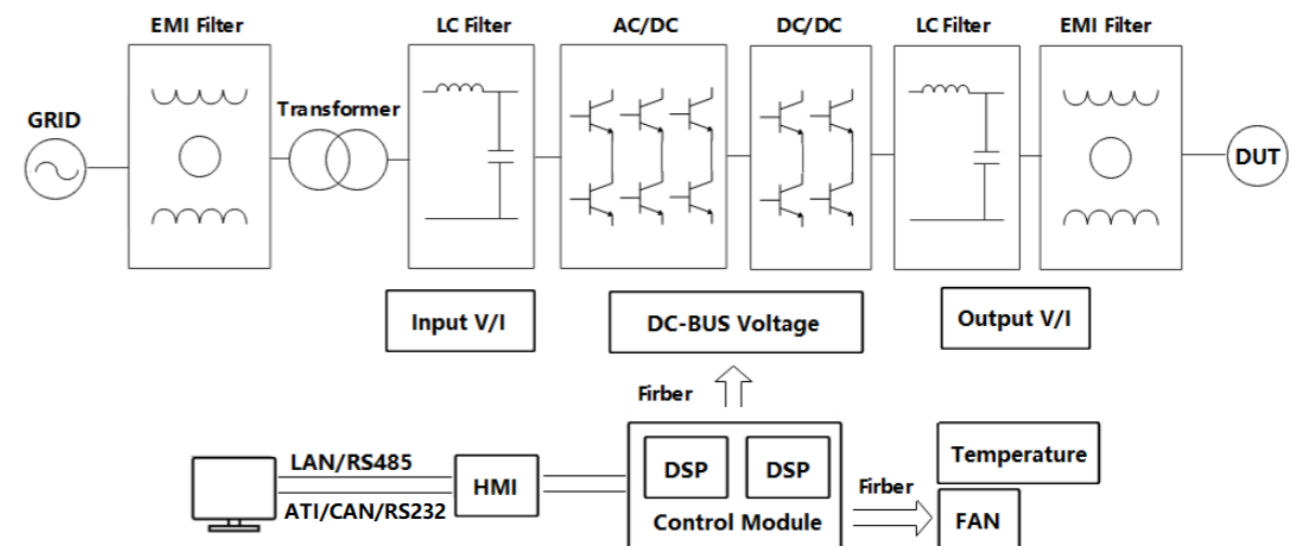

## General Specification

(customized unit specification will be shown in the proposal)

<b>AC Input</b>	
AC input Voltage	3P+N+PE, 380VLL±10%(std)
Frequency	47-63Hz
Efficiency	≥90%
Power Factor	0.95

<b>Output</b>	
Output Modes	CV, CC, CP and CR
Power Level	Up to 500kW in single controller, customized to 4MW and above
Voltage Ranges	Up to 2000V
Current Ranges	Please refer to the Standard Models Specification
Load Regulation	0.1%FS
Line Regulation	0.1%FS
Voltage Ripple	0.1%FS; 0.05%FS@2000V
Stability	0.1%FS
Current Rise Time (0~90%)	<3ms (Std), <1ms (BSS Option)
Current Rise Time (-90%~90%)	<5ms (Std), <2ms (BSS Option)
Voltage Regulation Time	<3ms (Std), <1.5ms (BSS Option) (0-100% Load change)
Power Accuracy	0.3%FS
Voltage Accuracy	0.1%FS

Current Accuracy	0.3%FS
Power Resolution	0.02kW (~100kW), 0.1kW (100kW~500kW)
Voltage Resolution	0.05V (~800V), 0.1V (800V~2000V)
Current Resolution	0.05A (~800A), 0.1A (800A~1600A), 0.2A (1600A~3200A)
Over Current	120%, 60 seconds

<b>Measurements</b>	
Measurement accuracy Power	0.3%FS
Measurement accuracy Voltage	0.1%FS
Measurement accuracy Current	0.3%FS

<b>Others</b>	
Standard Interface	LAN/RS485
Optional Interface	CAN/RS232/AT1
Protection	OVP, OCP, OPP, OTP
CE Conformity	EN 62040-1, EN 62040-2
Cooling	Forced Air Cooling
Temperature	Operating: 0~40°C, Storage: -20~85°C
Operating Humidity	up to 90%RH (None Condensing)
Protection Level	IP21

### Note:

1. Other Power/Voltage Level can be offered. Please consult factory
2. Total weight < 1400KG, the cabinet bottom is wheel structure; otherwise, it is channel steel structure.

## Options

- 232 RS232 program interface
- BSS Hardware and software for Battery simulation
- CAN CAN-bus program interface
- LD Regenerative DC load function
- PV Hardware and software for PV Simulation
- R Regenerative mode
- ATI Analog control interface (0~5V)
- ZV Low Voltage Operation Mode
- MS Master-Slave interface
- W Use water-cooling
- INS Output terminal insulation monitoring function
- CH(x) x channels output
- XXXXX Special request (refer to 5-digit number in the quote)

## AC Input Configuration <sup>1</sup>

Please specify the input voltage (L-L)

/380, Input Voltage 380V±10%, 3-phase

/400, Input Voltage 400V±10%, 3-phase

/480, Input Voltage 480V±10%, 3-phase

## Model Configuration

ESD AAA-BBB-CCC-DDD/EEE

AAA: Power, kW

BBB: Voltage range, V

CCC: Current range, A

DDD: Option

EEE: Input configuration

## About BriPower

Bridge Technology is a company focusing on business of **power supplies and test systems for new energy applications**. We are devoted to providing high quality products and solutions for customers.

Bridge Technology has a **top-class R&D team** in China, works on modularization and standardization power supplies and systems. We have sales, technical support, R&D and manufacture in Shanghai, Nanjing and Chengdu.

**Nanjing Bridge New Energy Technology** was founded on Jan 12th, 2016, focusing on R&D and manufacturing BriPower brand power systems, including bi-directional AC sources for grid simulation, bi-directional DC sources for battery simulation, and regenerative loads. The BriPower AC&DC power systems are widely used in new energy and related fields. **BriPower is valuable to customer especially High Power and High Voltage.**

Factory:	Nanjing Bridge New Energy Technology Co., Ltd
Sales Company:	Shanghai Bridge Electronic Technology Co., Ltd
General information:	info@bridgetech.cn
Technical Support:	support@bridgetech.cn
Repair & Calibration:	service@bridgetech.cn
Tel:	40010-18618
Int'l Sales:	contact@bridgetech.com.sg

<sup>1</sup> other AC input is available, please consult factory.